

SV-A100
SV-A125

Classic Glass

SV-A100 / A125 son sistemas de puertas correderas de vidrio suspendidas, sin marco y de alta calidad. Ideal para divisiones y puertas de uso doméstico o comercial de peso medio.

CARACTERÍSTICAS

Aplicación para hojas de 100 y 125 kg de peso por hoja respectivamente con distintas opciones de perfilera superior e inferior según las necesidades de cada instalación. También cuenta con opciones para panel fijo (F) gracias a la adición de los perfiles para dicha solución. Pinzas de alta calidad y rodamientos a bolas con las roldanas

de nylon para asegurar un deslizamiento excepcionalmente suave y silencioso.

Ajuste vertical habitual de la gama Saheco, concretamente para este sistema de +/- 5 mm. Disponibilidad de 3 tipos de guidores inferiores.

SV- A100/A125 (opción vidrio fijo): Idéntica a la opción estándar pero con un perfil complementario superior para instalaciones de hoja corredera y hoja fija.

No se requiere mecanización del vidrio en ninguna de las soluciones.

Características técnicas

Pictogramas

Perfilería



38x40,5 mm



84x40,5 mm



20x20 mm



12x17 mm



20x15 mm

Especificaciones



8-12 mm



8 mm > 16 mm
10 mm > 14 mm
12 mm > 12 mm



RODAMIENTO
A BOLAS

Opciones pinza



SV-3



SV-4

Pesos

100 kg

125 kg

Variantes de instalación

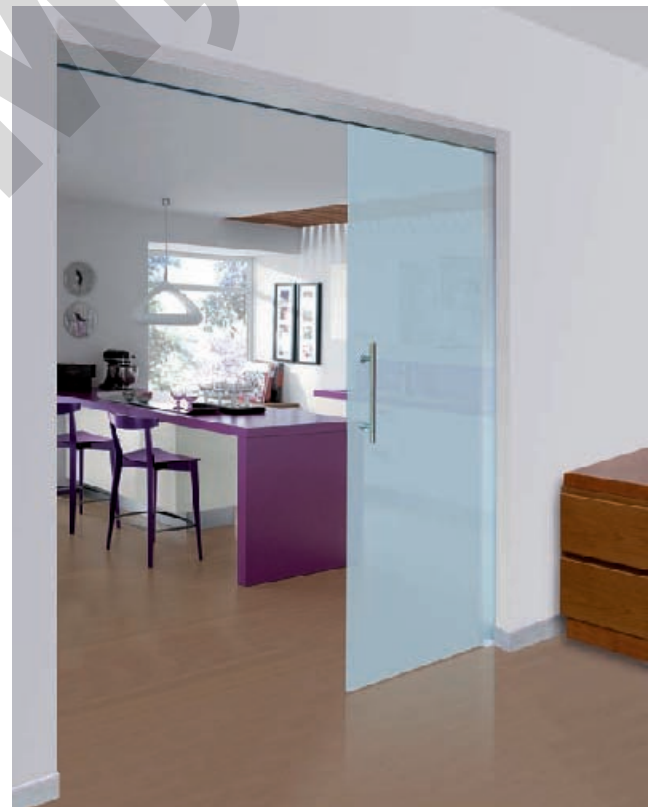
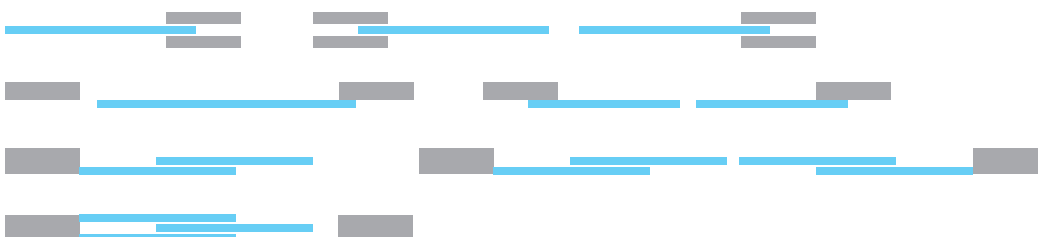

DIVISIONES Y PUERTAS CORREDERAS - CLASSIC GLASS

SECCIÓN TIPO



SV - A100



Montaje a pared

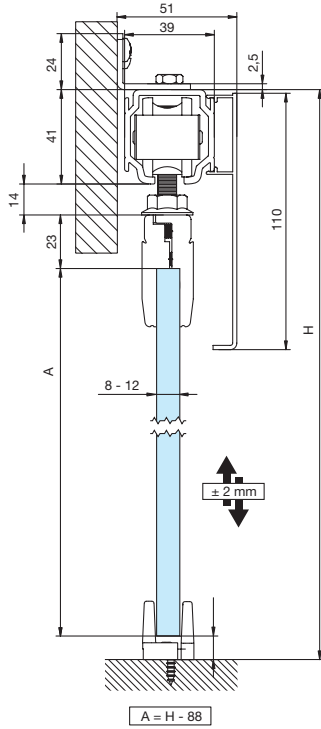

Cotas en mm

SV - A100



Montaje a techo

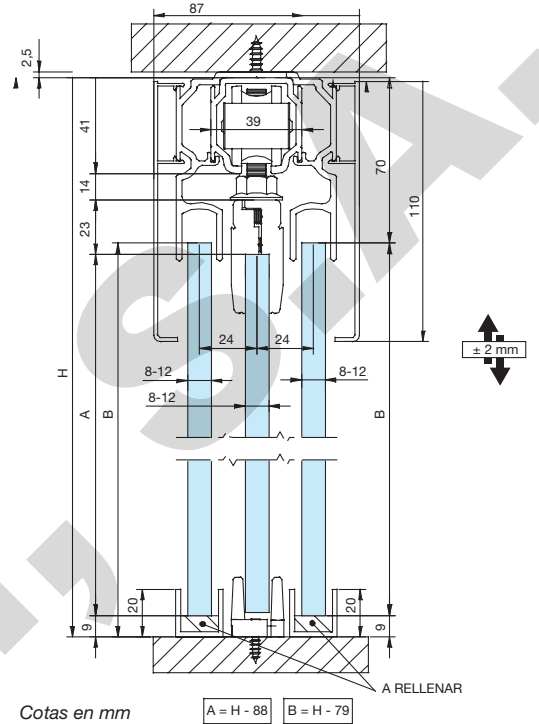

Cotas en mm

SV - A125



Montaje a pared

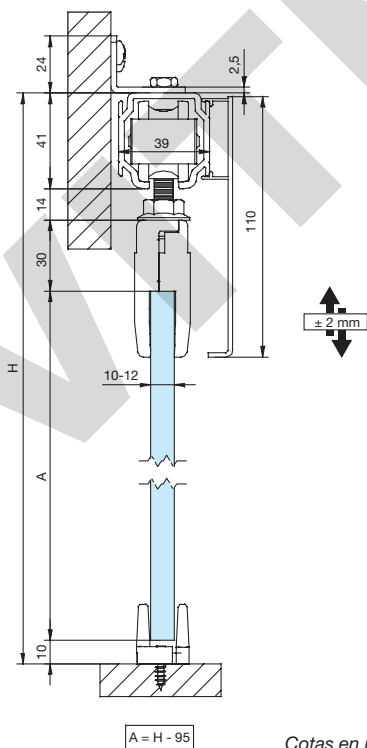

Cotas en mm

Montaje a falso techo

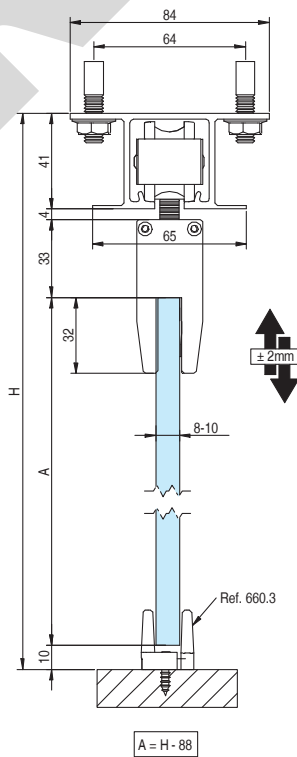

Cotas en mm

SV - A125





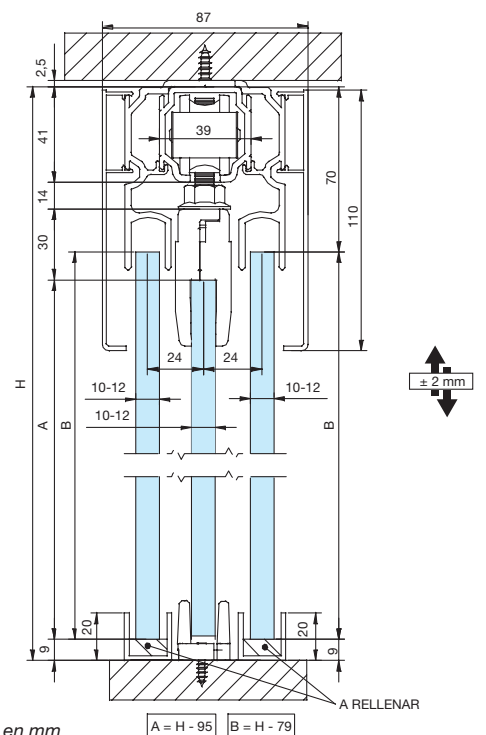







Montaje a techo

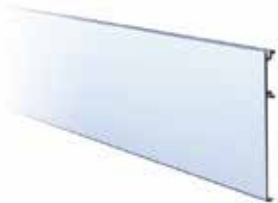

Cotas en mm

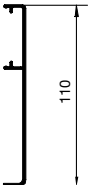
MECANISMOS PARA PUERTAS CORREDERAS

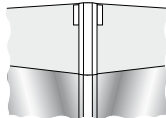
CLASSIC GLASS SV-A100 / SV-A125







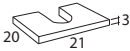

DESCRIPCIÓN	REFERENCIA		
PERFIL AÉREO PARA 100 / 125 kg			126/21 126/31 126/51 126/20 126/30 126/50
Acabado: Aluminio natural			
Longitud: 2000 mm	2930.2		
3000 mm	2930.3		
5000 mm	2930.5		
Acabado: Anodizado plata			
Longitud: 2000 mm	2930.2 PL		
3000 mm	2930.3 PL		
5000 mm	2930.5 PL		
			38x40,5 mm
PERFIL VIDRIO FIJO			103/01 103/20 103/30 103/50
Acabado: Anodizado plata			
Longitud: 100 mm	2926.0 PL		
2000 mm	2926.2 PL		
3000 mm	2926.3 PL		
5000 mm	2926.5 PL		
			47 x8 1m m
PERFIL TAPA			104/20 104/30 104/50 104/21 104/31 104/51 104/22 104/32 104/28 104/38
Acabado: Anodizado plata			
Longitud: 2000 mm	2927.2 PL		
3000 mm	2927.3 PL		
5000 mm	2927.5 PL		
Acabado: Lacado blanco			
Longitud: 2000 mm	2927.2 BL		
3000 mm	2927.3 BL		
5000 mm	2927.5 BL		
Acabado: Plata brillo			
Longitud: 2000 mm	2927.2 PB		
3000 mm	2927.3 PB		
Acabado: Efecto inox mate			
Longitud: 2000 mm	2927.2 IN 		
3000 mm	2927.3 IN		
			110
JUEGO ESQUINERAS PARA PERFIL TAPA			103/02 103/03 103/04
Material: Plástico			
Acabados: Plata	2930.6 PL		
Blanco	2930.6 BL		
ANULADO Efecto inox mate	2930.6 IN		
			
PERFIL AÉREO FALSO TECHO			126/22 126/32 126/52
Acabado: Anodizado plata			
Longitud: 2000 mm	2931.2 PL		
3000 mm	2931.3 PL		
5000 mm	2931.5 PL		
			FT 84x40,5 mm

MECANISMOS PARA PUERTAS CORREDERAS CLASSIC GLASS SV-A100 / SV-A125

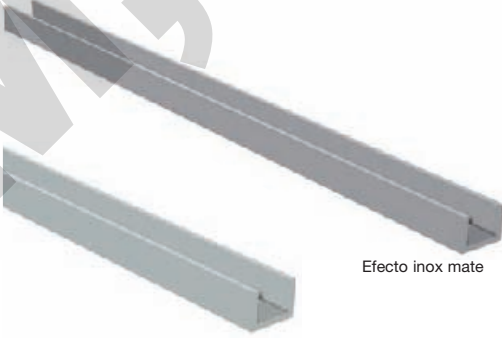

DESCRIPCIÓN	REFERENCIA		
JUEGOS COMPLETOS DE ACCESORIOS Vidrio 8/12 mm Para 100 kg Vidrio 10/12 mm Para 125 kg	670 672		116/00 126/00 SV-3 SV-4
<i>No compatibles con softbrake</i>			
ROLDANA CON TORNILLO REGULADOR Para 100 kg Para 125 kg	670.1 672.1		116/55 126/55 RODAMIENTO A BOLAS
PINZA REGULABLE Vidrio 8/12 mm Para 100 kg Vidrio 10/12 mm Para 125 kg	670.2 672.2		101/58 125/58 SV-3 SV-4
FRENO RETENEDOR	670.4		116/57
GUÍA INFERIOR PLÁSTICO Vidrio 8/10/12 mm	660.3		40/57
GUÍA INFERIOR ALUMINIO Vidrio 8/10/12 mm Acabados: Anodizado plata Efecto inox mate	2877 PL 2877 IN	Anodizado plata Efecto inox mate	42/57 42/58
SOPORTE LATERAL PEQUEÑO SOPORTE LATERAL GRANDE	671 671.1		116/58 116/59

MECANISMOS PARA PUERTAS CORREDERAS CLASSIC GLASS SV-A100 / SV-A125

DESCRIPCIÓN	REFERENCIA		
SEPARADOR COMPENSADOR DE ALUMINIO	2916.1		60/61
			
EMBELLECEDOR FINAL DE PERFIL	2930.7		125/57
SOPORTE PARA TAPA DE MADERA	664		66/59
PERFIL INFERIOR PARA VIDRIO FIJO Vidrio 8/10 mm			87/24 87/34 87/54 84/24 84/34 84/54
Acabado: Anodizado plata			
Longitud: 2000 mm	2951.2 PL		
3000 mm	2951.3 PL		
5000 mm	2951.5 PL		
Acabado: Efecto inox mate			
Longitud: 2000 mm	2951.2 IN		
3000 mm	2951.3 IN		
5000 mm	2951.5 IN		
		Anodizado plata	
		Efecto inox mate	12x17 mm
PERFIL INFERIOR PARA VIDRIO FIJO Vidrio 8/10/12 mm			87/30 87/60
Acabado: Anodizado plata			
Longitud: 3000 mm	2940.3 PL		
6000 mm	2940.6 PL		
			
			20x20 mm
PERFIL INFERIOR ALUMINIO CON CEPILLO Vidrio 8/10/12 mm			41/22 41/32 41/62
Acabado: Anodizado plata			
Longitud: 2000 mm	2939.2 PL		
3000 mm	2939.3 PL		
6000 mm	2939.6 PL		
			
			20x15 mm